



TAPARIA TOOLS LTD.

AN ISO-9001 COMPANY



CANTILEVER TOOL BOXES

CANTILEVER TOOL BOXES

- ★ For storing different types of tools, accessories etc.
- ★ Made from high gauge steel sheet for higher strength and long life.
- ★ Two steel handles for balanced and comfortable carrying.
- ★ Assembled with stainless steel rivets for extra strength and rust prevention.
- ★ Superior Powder coated for rust protection.
- ★ Provision for locking.
- ★ Boxes are available in 3 and 5 compartments.



5 Compartments



3 Compartments

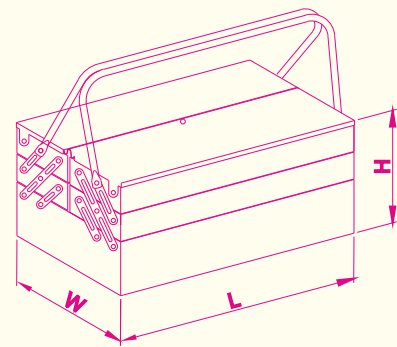

PRODUCT NO.	Dimensions in mm			Weight Carrying Capacity
	H	W	L	
CTB 1805	205	200	450	15 kgs. Max.
CTB 1803	155	200	450	10 kgs. Max.

BOX SPANNERS

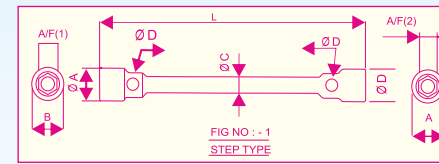

L TYPE SPANNERS

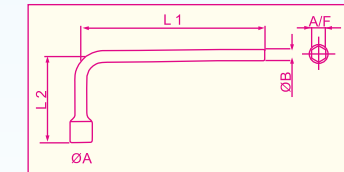

PROD. NO	FIG.NO	ØA	ØB	ØC	ØD	A/F(1)	A/F(2)	L	WT. KGS.
HD 1720	2	49	45	25	21.4	30	32	400	2.00
HD 1725	3	42	42	25	21.4	27	30	400	1.92
1728	1	42	38	23	21.4	24	27	400	1.53
HD 1730	2	49	42	25	21.4	27	33	400	1.90
1731	1	42	42	23	21.4	27	27	400	1.44
HD 3030	3	45	45	25	21.4	30	30	400	2.00
1740	1	50	50	23	21.4	32	32	400	1.80
CHD 1740	1	49	49	25	21.4	32	32	400	1.88
HD 3233	1	49	49	25	21.4	32	33	400	1.93
1741	1	50	50	23	21.4	33	33	400	1.58
HD 1741	1	49	46	25	21.4	33	33	400	1.94

PROD. NO	ØD	ØD	L	L	WT. GMS	
T1535	28	16	250	115	18	600
1536 S	30	16	250	115	19	610
1536	30	16	300	140	19	715
1537	32	16	310	140	21	755

Generally conforming to IS 2030-1989

PRODUCT NO. AND SIZE	S1	S2	ØD	L	WEIGHT GRAMS.
TS 6 X 7	6.0	7.0	9.2	115	35
TS 8 X 9	8.0	9.0	12.8	120	45
TS 10 X 11	10.0	11.0	12.8	125	65
TS 12 X 13	12.0	13.0	15.7	135	95
TS 14 X 15	14.0	15.0	15.7	140	120
TS 16 X 17	16.0	17.0	19.0	150	145
TS 18 X 19	18.0	19.0	22.0	160	160
TS 18 X 19	18.0	19.0	22.0	160	160
TS 20 X 22	20.0	22.0	25.0	170	225
TS 21 X 23	21.0	23.0	25.0	175	235
TS 24 X 27	24.0	27.0	28.5	185	285
TS 25 X 28	25.0	28.0	31.0	190	335
TS 30 X 32	30.0	32.0	35.0	205	480

(8 pcs.) with Tommy Bar :

Prod. No.	Contents
TS 08 (8 Pcs Set)	6x7, 8x9, 10x11, 12x13, 14x15, 16x17, 18x19, 20x22 Tommy Bar : 1) Dia 12 x 250 mm. 2) Special Tommy Bar
TS 12 (12 Pcs Set)	6x7, 8x9, 10x11, 12x13, 14x15, 16x17, 18x19, 20x22, 21x23, 24x27, 25x28, 30x32 Tommy Bar : 1) Dia 12 x 250 mm. 2) Special Tommy Bar

TUBULAR BOX SPANNERS



TUBULAR SPANNERS SET



TAPARIA TOOLS LTD.

Head Office : 423 / 424, A-2, Shah & Nahar, Lower Parel (W), Mumbai - 400 013. & : 6147 8600
 Fax : 91-22-2495 3230. • E-mail : sales@tapariatools.com • Web Site : http://www.tapariatools.com
 Works : 52-B, M. I. D. C., Satpur, Nashik - 422 007. & : 2350 317 / 318 / 418 CIN : L99999MH1965PLC013392



AN ISO-9001 - 2015 COMPANY

TAPARIA® TAPARIA® TAPARIA® TAPARIA® TAPARIA®